



Type 41LA

SPECIFICATION

- ▼ LED Lamp – 18W
- ▼ Wide Voltage Range 90 - 250V
- ▼ Two pin electrical interface to spec. 691/1984
- ▼ Approximate Weights – 17 Kg

CERTIFICATION & APPROVAL

SIRA02ATEX1407X I M2 EExd I

 I M2 EExd I

Ambient Temperature range:

-15°C To +50°C

FEATURES & BENEFITS

- ▼ Supplied with Long Life LED Lamp
- ▼ LED Lamp offers greater than 50,000 hours continuous lamp life
- ▼ Quick re-lamp. Lampglass secured with single bolt and if necessary can be removed completely by withdrawing two split pins.
- ▼ Simple installation using Victor range of LP plugs designed to NCB Spec. 691/1984
- ▼ Protected against dust and water ingress.
- ▼ Guard option available.
- ▼ Casting made from zinc alloy to reduce weight and avoid rusting.
- ▼ No control gear required



Victor

VICTOR PRODUCTS LIMITED

New York Way, New York Industrial Park, Newcastle upon Tyne, NE27 0QF United Kingdom
Tel: 0191 280 8000, Fax: 0191 280 8080 Email: sales@victor.co.uk Web: www.victor.co.uk

A Federal  Signal Company

DIMENSIONS

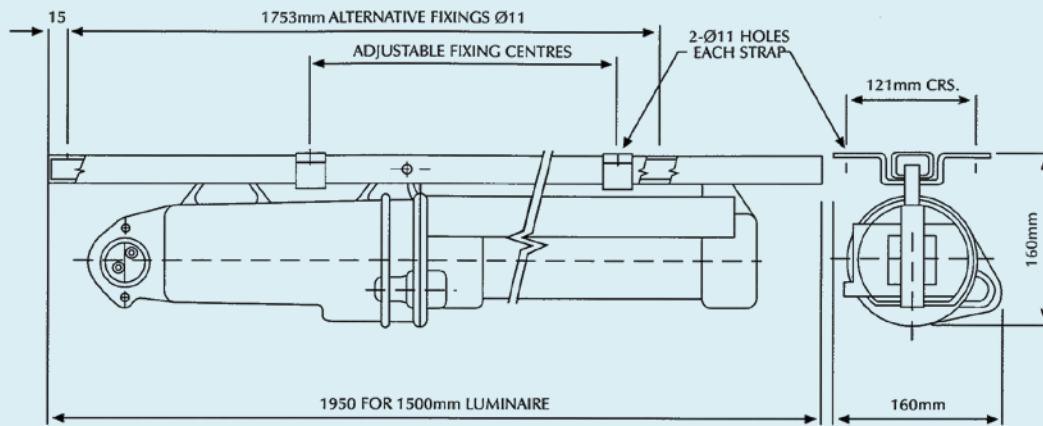

Dimensions in millimetres

Installation Leaflet ML193135

TYPICAL ORDERING REFERENCES

ORDERING REFERENCE	DESCRIPTION
ML041A	41LA 5ft LED Luminaire 90 – 250V – 18W

SPARES

ORDERING REFERENCE	DESCRIPTION
ML193133	5ft LED Tube – 18W

ACCESSORIES

Accessories required for complete lighting system

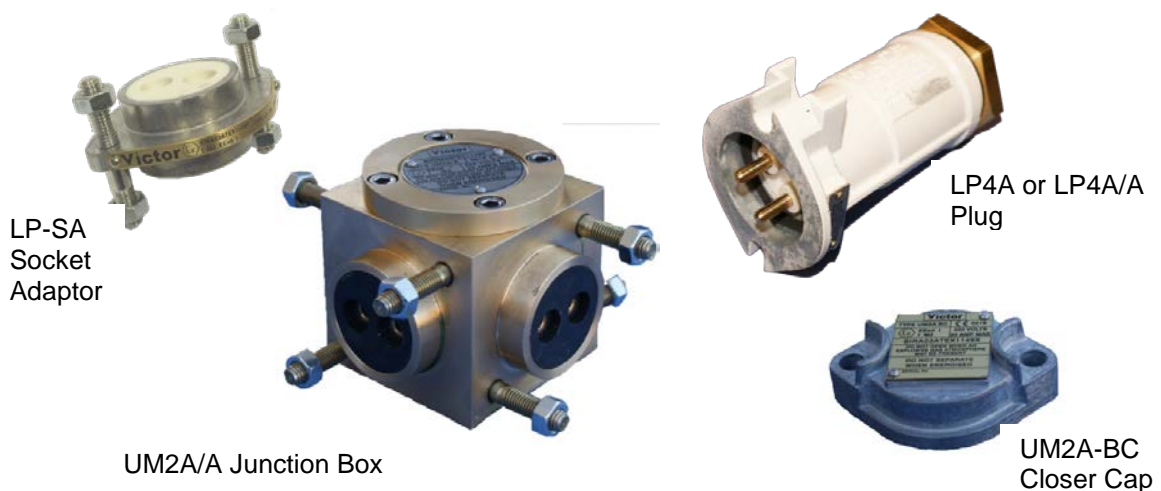

LP-SA
Socket
Adaptor

UM2A/A Junction Box

LP4A or LP4A/A
Plug

UM2A-BC
Closer Cap

Contact Victor Products Ltd Sales department for further details.



Victor

VICTOR PRODUCTS LIMITED

New York Way, New York Industrial Park, Newcastle upon Tyne, NE27 0QF United Kingdom
Tel: 0191 280 8000, Fax: 0191 280 8080 Email: sales@victor.co.uk Web: www.victor.co.uk

A Federal  Signal Company