

PLLE Series LED Luminaire

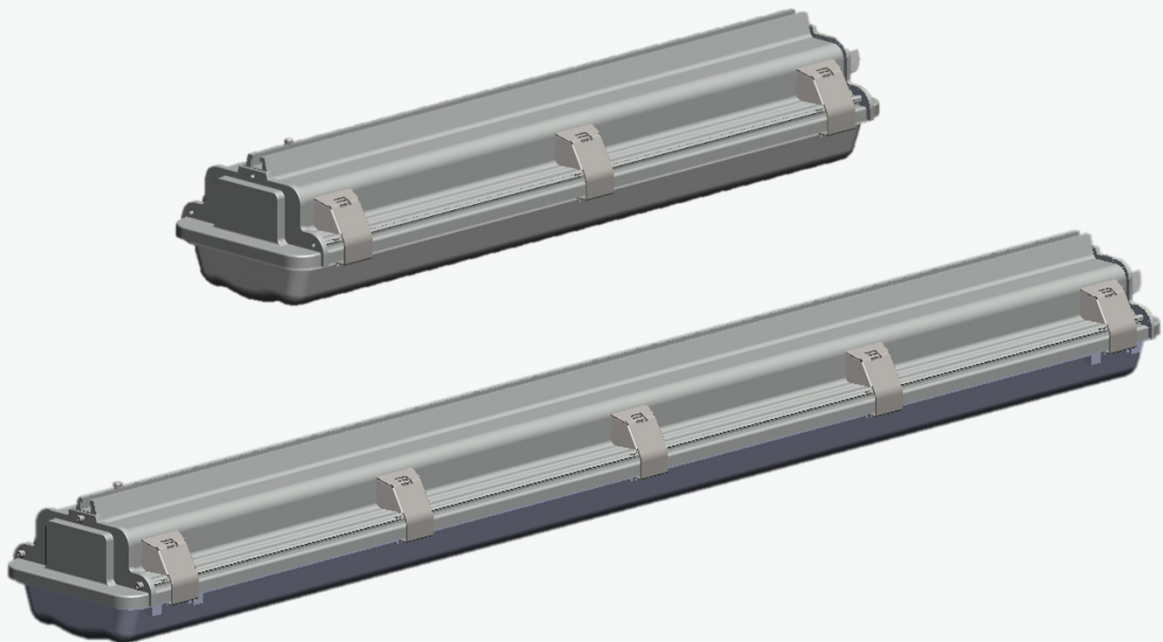

Powering Business Worldwide

1. DIMENSIONS

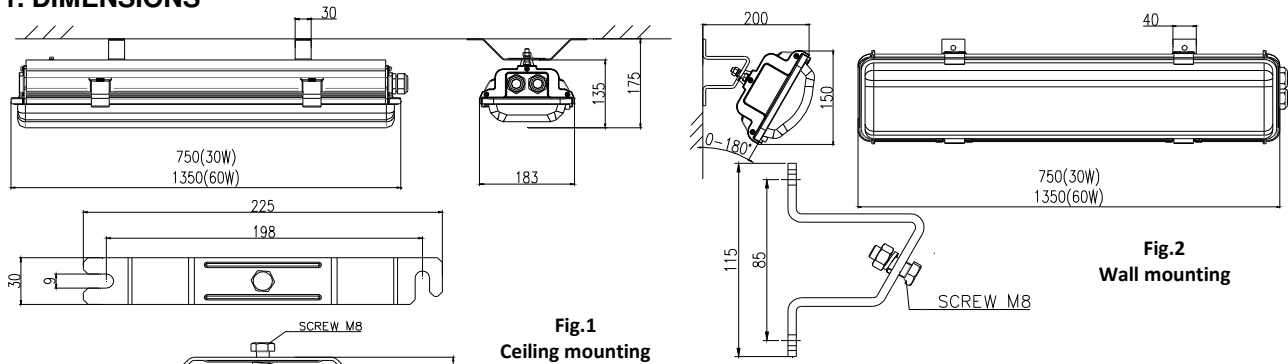

Fig.1
Ceiling mounting

Fig.2
Wall mounting

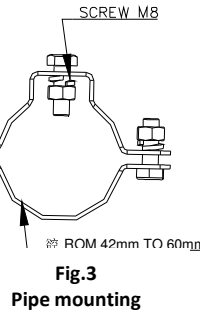

Fig.3
Pipe mounting

2. Safety Instructions

- This product should be installed, inspected, and maintained by a qualified electrician only, in accordance with national regulation, including the relevant standard and, where applicable. The national safety rules and regulations for prevention of accidents and the following safety instructions in these operating instructions, will have to be observed!**
- ❖ Do not operate in ambient temperatures above those indicated on the luminaire nameplate.
 - ❖ The luminaires shall be operated as intended and only in undamaged and perfect conditions! And Keep tightly closed when in operation!
 - ❖ The technical data indicated on the luminaire are to be observed!
 - ❖ Change of the design and modifications to the luminaire are not permitted!
 - ❖ Multiple, short-term switching must be observed!
 - ❖ Only genuine Eaton Crouse-Hinds spare parts may be used for replacement!
 - ❖ Repairs that affect the explosion protection, may only be carried out by Eaton Crouse-Hinds or qualified electrician!

3. Technical data

Enclosure specification	
Material of enclosure:	Aluminum alloy
Finish:	Polyester power coating or anodizing
Material of cover:	PC
Mounting bracket:	Stainless steel or Steel painted
Fasteners:	All external fasteners stainless steel
Installation:	Mounting bracket
Weight:	Refer to Type Configuration.
Entry specification	
Indirect entry: M20 × 1.5 or M25 × 1.5 cable entry.	
Electrical specification	
Wattage:	30W/40W/60W/80W
Voltage:	100-240Vac 50/60Hz, 108-250Vdc
Lamp:	LED Arrays
Lumen output at emergency	25%/20%
Emergency time	1.5h/3h
CRI:	70
Insulation class:	I acc. to IEC60598
Terminals capacity:	4mm ² /6mm ² Terminal

4. Fields of Application

The Luminaire is IP66 making it suitable for areas in indoors and outdoors in Marine and Wet locations, where moisture, dirt, corrosion, vibration and rough usage may be present. Application ambient temperature is -40°C~+55°C or -25°C~+55°C. The enclosure materials used, including any external metal parts, are high quality materials that ensure a corrosion resistance and resistance to chemical substances according to the requirements for use in a "normal" industrial atmosphere. In case of use in an extremely aggressive atmospheres, please refer to manufacture.

5. Installation

5.1 General

The respective national regulations as well as the general rules of engineering which apply to the installation and operation of apparatus will have to be observed!

The improper installation and operation may result in the invalidation of the guarantee.

5.2 Mounting luminaire

5.2.1 Mounting the bracket

Only use the accompanying mounting bracket! Securely fasten the mounting bracket to a suitable base with sufficient load-bearing capacity. The mounting should be secured with M8 bolts and relative lock washers, nuts should be used.

The minimum distance between the luminaire and illuminated surface, directly in front of the luminaire, is 0.5 meter. The lamp must not be illuminated when at a distance of less than 0.5m from inflammable material

5.3 Cable entries/Plugs and Breathing valve

Unused holes must be closed with certified plug. **Cable entries sealing washer(if required by manual of cable gland/plug) must be used to obtain IP66.**

The authoritative mounting guidelines for the cable glands and breathing valve used must be observed. Mounting the selected cable entries acc. type and dimensions of the main connection cable following their manufacturer instructions. Only heat resistant cable according to the data on the type label may be used! The max. conductor size is 6mm².

5.4 Opening/closing the luminaire

5.4.1 General

The opening of luminaire always shall be without voltage! All gasket seals must be clean and undamaged before closing the luminaire. Make sure the luminaires is well closed before operation!

5.4.2 Terminal chamber cover

Open the buckles and remove the PC cover. And carry out the steps in reverse order to close the luminaire. Check all buckles to ensure a secure fit during operation .

5.5 Electrical connection

The electrical connection of the lamp must only be established by qualified electricians. Make sure the supply voltage is the same as the luminaire voltage! Use proper supply wiring as specified on the nameplate of the luminaire and in this instructions! Excessive tightening may affect or damage the connection.

5.5.1 Wire connection

The conductors shall be connected with special care. The conductor itself shall not be damaged. The connectible min. and max. conductor cross-sections shall be observed (see technical data). All terminals, used and unused, shall be fully tightened to prevent incorrect selection between 1.2Nm for Exe T 6P and 1.5~1.8Nm for MBK. Main connection: See wiring diagram. **See Fig.4 for details.**

6. Putting into operation

Prior to putting the apparatus into operation, the tests specified in the relevant national regulations shall be carried out. Insulation measurements may only be carried out between PE and the external conductor L1 (L2, L3) as well as between PE and N.

- Measurement voltage: Max. 1.5 KV AC
- Measurement current: Max.5 mA
- The luminaire may only be operated when closed.

7. Maintenance/Serviceing

7.1 General

The relevant national regulations which apply to the maintenance/servicing of electrical apparatus shall be observed. The interval between maintenance depends upon the ambient conditions and the hours of operation.

7.2 Checks

The equipment must be de-energised before opening.

Visual inspection should be carried out at a minimum of 12 monthly intervals and more frequently if conditions are severe. The time between lamp changes could be very infrequent and this is too long a period without inspection.

7.3 Routine Examination

During maintenance, the parts affecting the level of protection must be checked in particular:

- Ensure the lamp is lit when energised and examine the enclosure and glass for any signs of cracks and damage.
- When de-energised and left to cool, there should be no significant sign of internal moisture. If there are signs of water ingress, the luminaire should be opened up, dried out, and any likely ingress points eliminated by re-gasketing, re-greasing or other replacement.
- Check the gasket of pc cover and LED housing for any damage or permanent set and replace as required.
- Terminal, screw glands and blanking plugs for secure fitting.
- To maintain the light output, clean the protective pc cover periodically with a damp cloth or a mild cleaning fluid.
- If this product is used in the combustible dust area, outside of enclosure must be cleaned on a regular basis to prevent accumulation of dust.
- The cable connections should be checked for tightness. The gasket should be checked for cracks or lack of elasticity, and if necessary, replaced.
- Check that mountings are secure and the adjusting bolts are tight.

10. Type configuration

Std. Cat No.	System power	Voltage(V)	Weight (Kg)	Output at emergency
PLLE-2-W*-2L-*	30W	100-240Vac 50-60Hz 108-250Vdc	6	25%output 1.5H, 3H
PLLE-2-W*-2L-EM*-*			7	
PLLE-2-C*-3L-*			6	20%output 3H
PLLE-2-C*-3L-EM*-*			7	
PLLE-2-W*-3L-*	6			
PLLE-2-W*-3L-EM*-*	7			
PLLE-2-C*-4L-*	40W		6	25%output 1.5H, 3H
PLLE-2-C*-4L-EM*-*			7	
PLLE-4-W*-4L-*	60W	10	20%output 3H	
PLLE-4-W*-4L-EM*-*		12		
PLLE-4-C*-5L-*	80W	10	25%output 1.5H, 3H	
PLLE-4-C*-5L-EM*-*		12		
PLLE-4-W*-7L-*		10	20%output 3H	
PLLE-4-W*-7L-EM*-*		12		
PLLE-4-C*-8L-*	10	25%output 1.5H, 3H		
PLLE-4-C*-8L-EM*-*	12			

- If it has been suspected that the luminaire has mechanical damage, a stringent workshop overhaul will be required. Where spares are needed, these must be replaced with factory specified parts.
- No modifications should be made without the knowledge and approval of the manufacturer.

8. Repair/Overhaul/Modifications

8.1 General

The national regulations have to be observed! Repairs and overhaul may only be carried out with genuine Eaton Crouse-Hinds spare parts.

In the case of battery failure, the battery pack must be replaced as a complete unit from the manufacture.

Before replacing or disassembling individual parts, observe the following:

Disconnect the power supply to the equipment before maintenance/repair.

See section 5.4 for notes on opening and closing the lamp.

Only use original spare parts. If the luminaire was previously in operation then wait to cool enough before opening. Modifications to the device or changes to its design are not permitted.

Assistance may also be obtained through Cooper Electronic Technologies (Shanghai) Co., Ltd. Sales Service department,
955 ShengLi Road, Pudong Shanghai 201201
Phone (86) 21-28993943

9. Disposal/Recycling

When the apparatus is disposed of, the respective national regulations on waste disposal will have to be observed.

